

Cost Reduction Initiatives



**Low Voltage Un-armoured Power,
Control and Instrumentation Cables**



Presentation Format

- **The Shearwater Project**
- **The Challenge**
- **Design Development**
- **Cost Savings**



Alliance Members

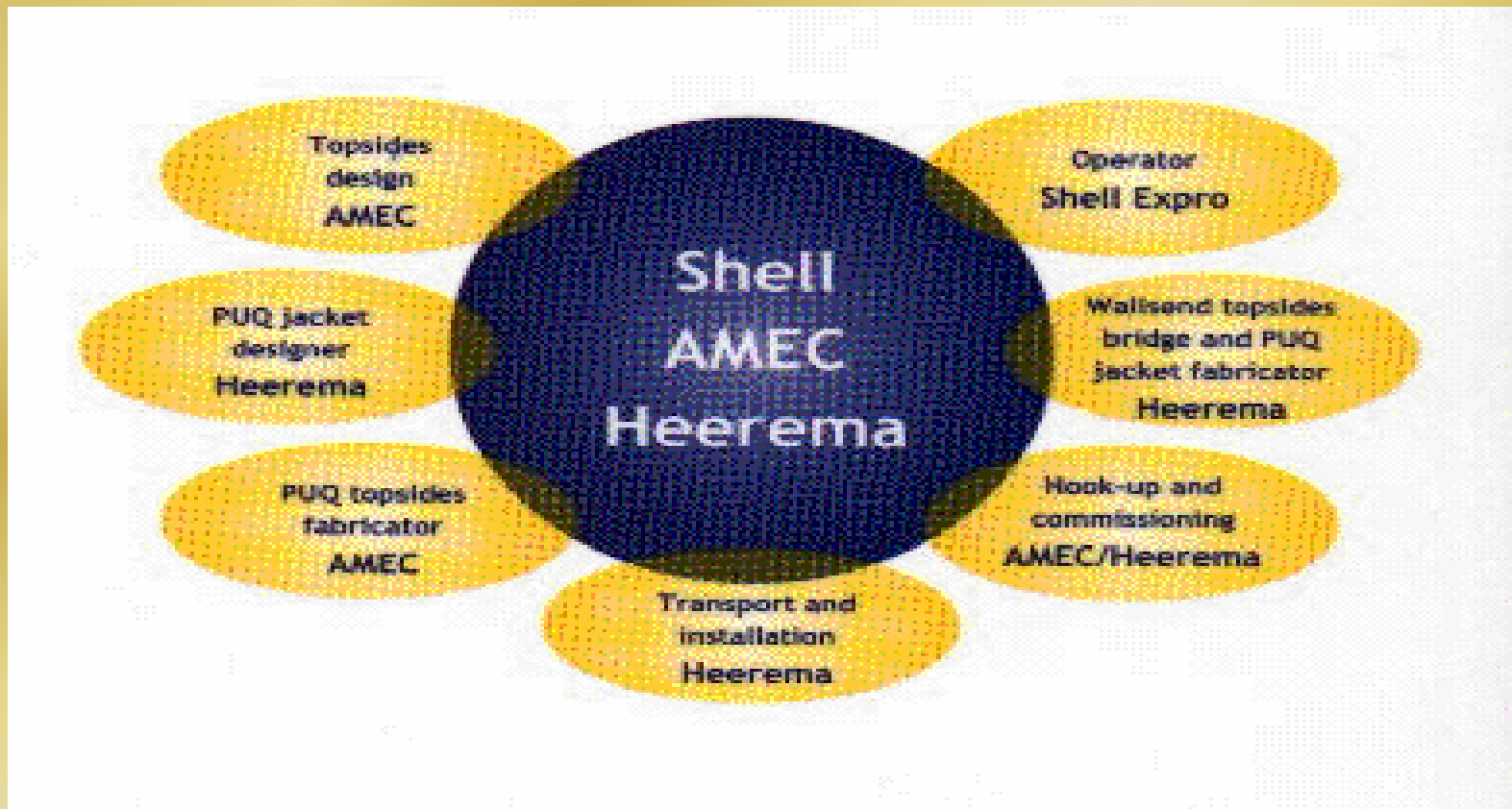

The Shearwater Project

Location

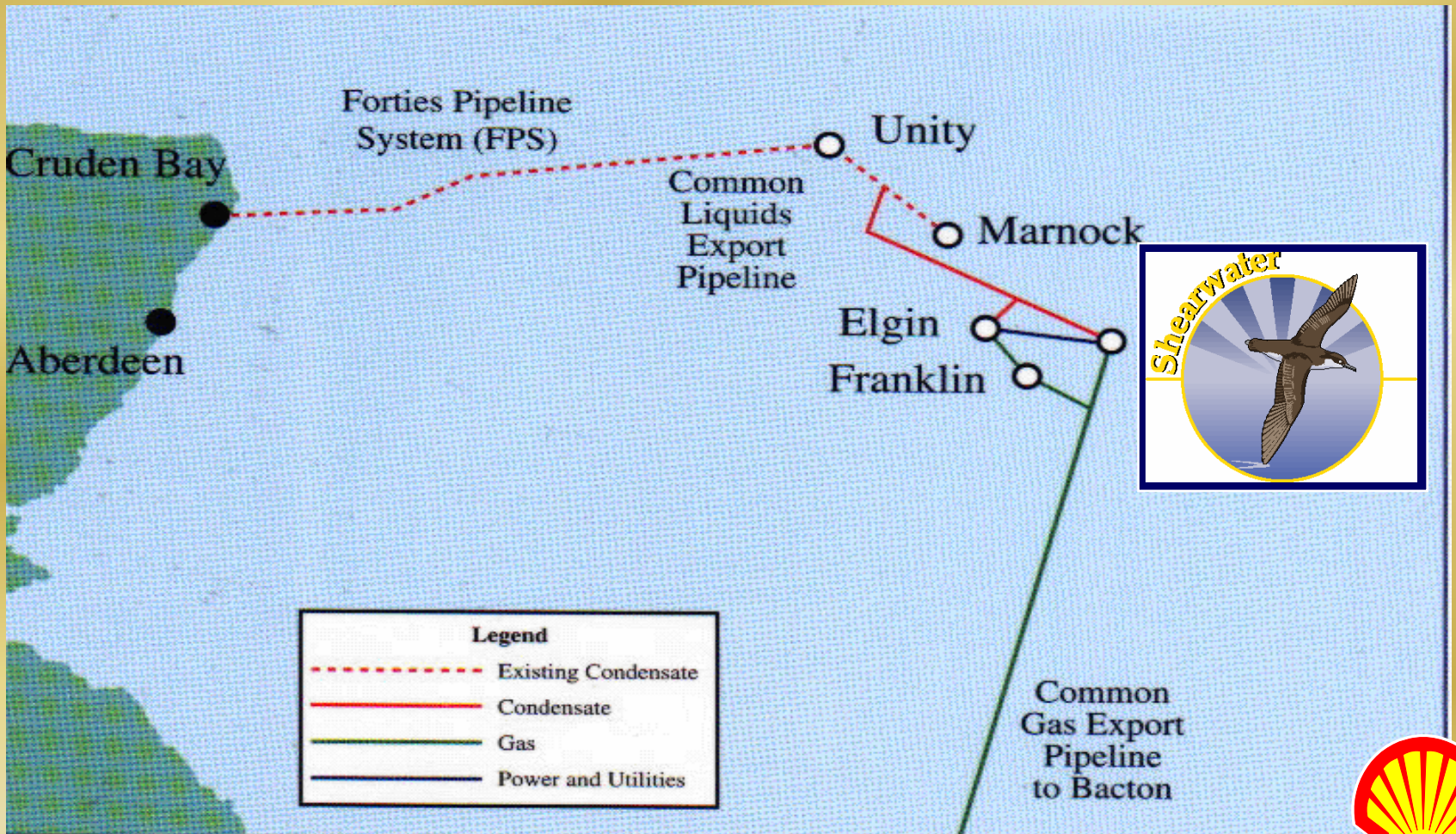

The Shearwater Challenge

- To question the conventional practice of employing the extensive use of braid armoured cables on offshore installations.
- To consider the use of low voltage unarmoured power, control and instrumentation cables throughout a platform.



The Scenario

To move away from the standard armoured product to the widespread use of unarmoured products throughout the platform

Armoured

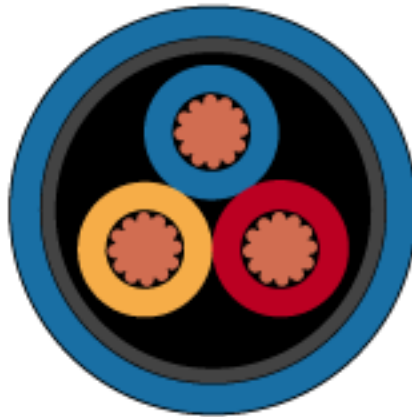

Un-armoured

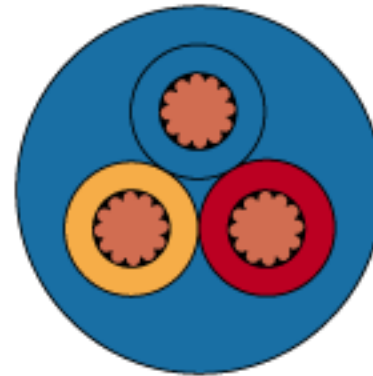

Why ?

- The galvanised steel wire braid is a poor electrical conductor.
- In the event of an earth fault the electrical contribution of the GSWB is negligible due to the high A.C. resistance of the braid under fault conditions.
- The inclusion of a protective earth conductor in power cables and omitting the braid for all Low Voltage and Instrument circuits could result in overall cable installation savings of between 40 and 50%.



Primary Cable Support Racking

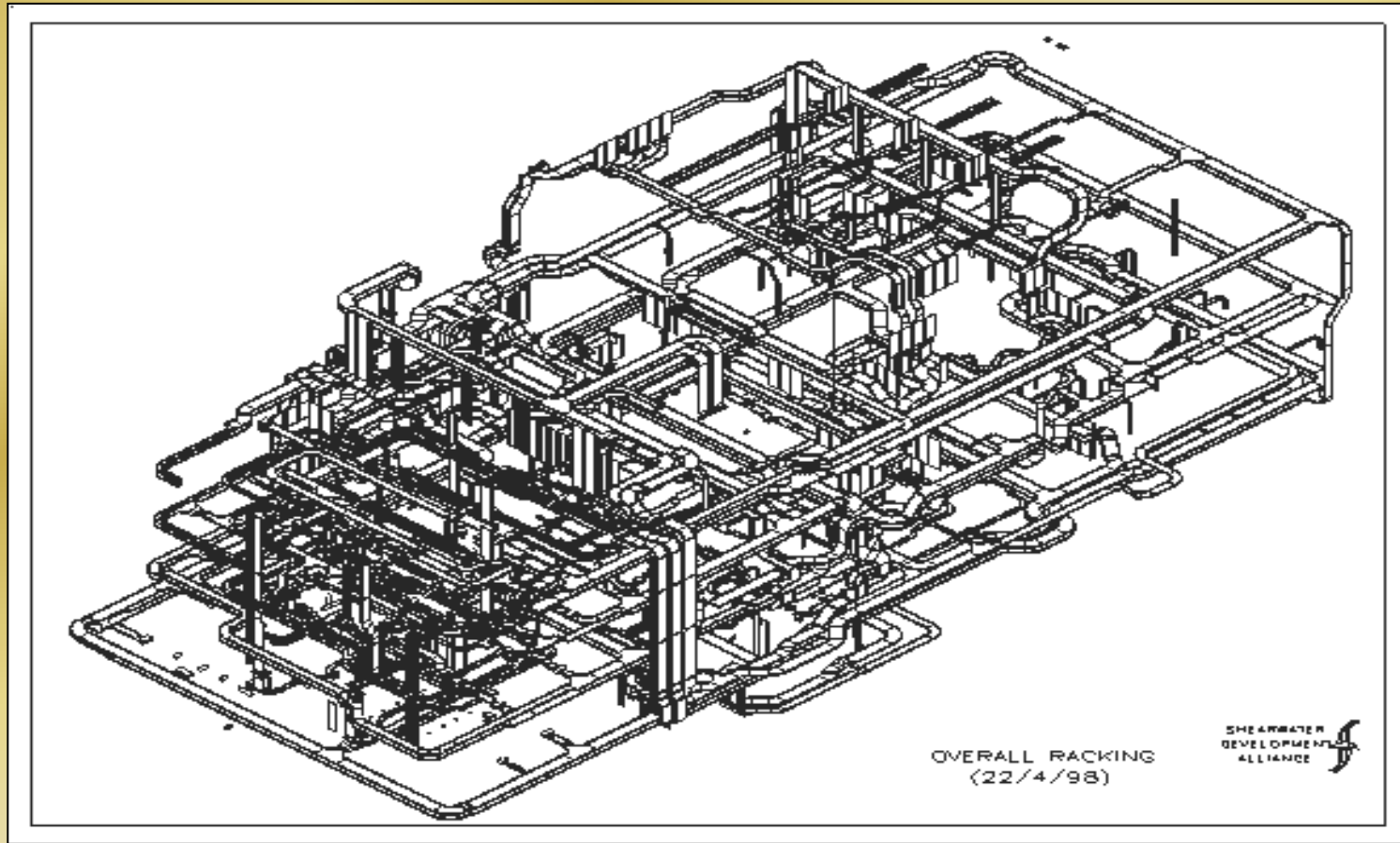

LV Single Phase Earth Fault

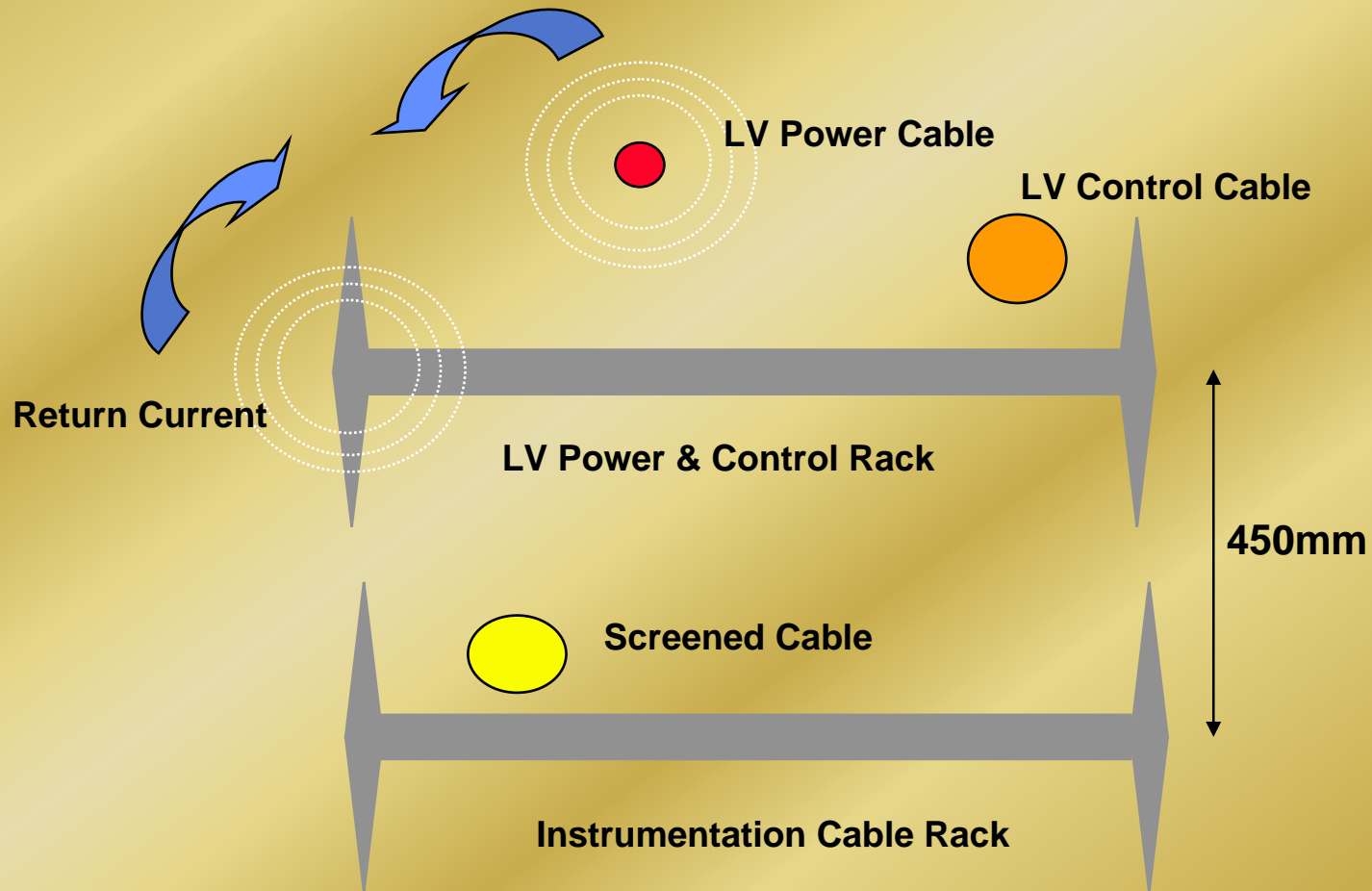

Current sharing between GSWB and adjacent metallic surface

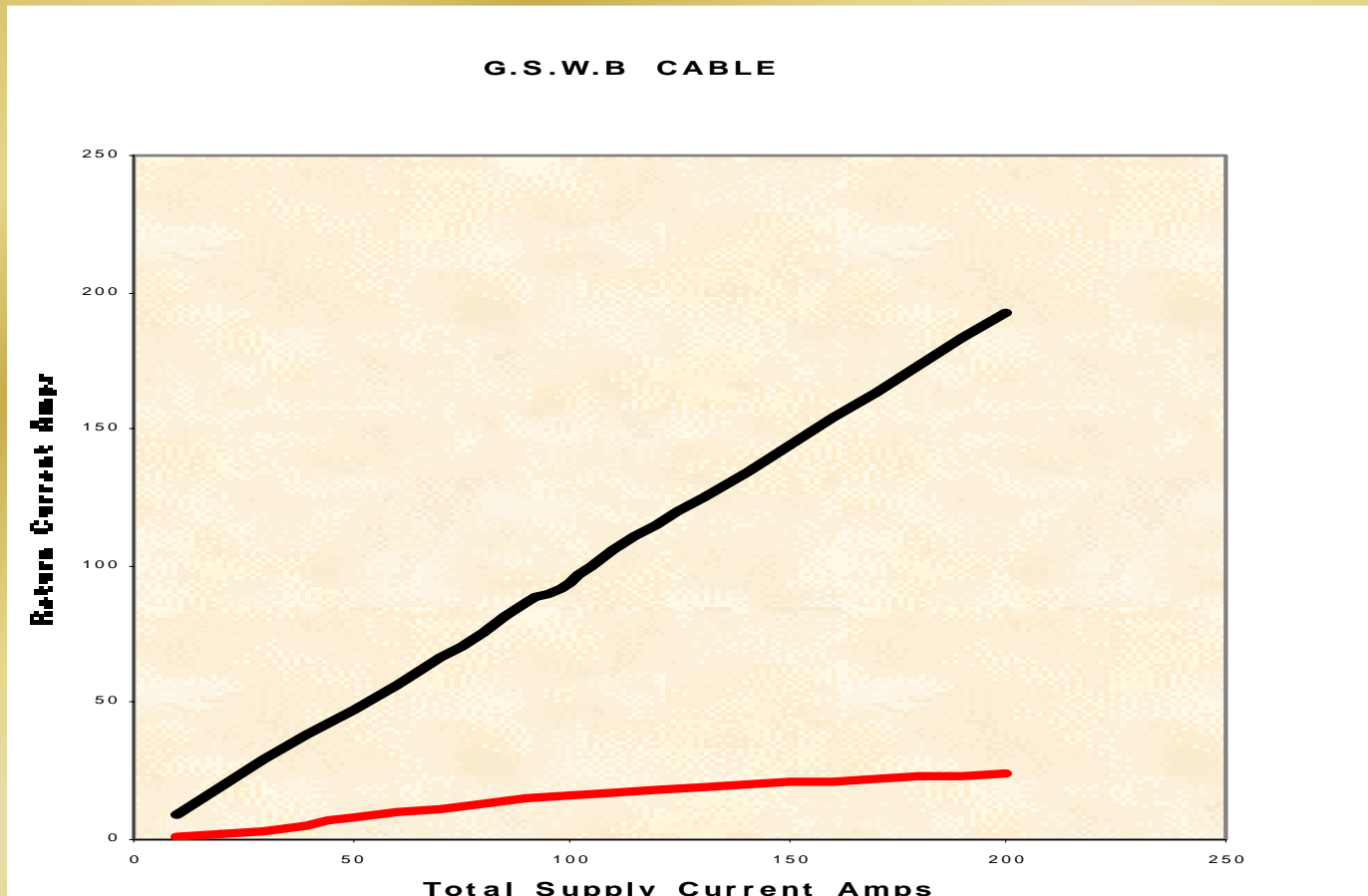

Current Density in Adjacent Steel

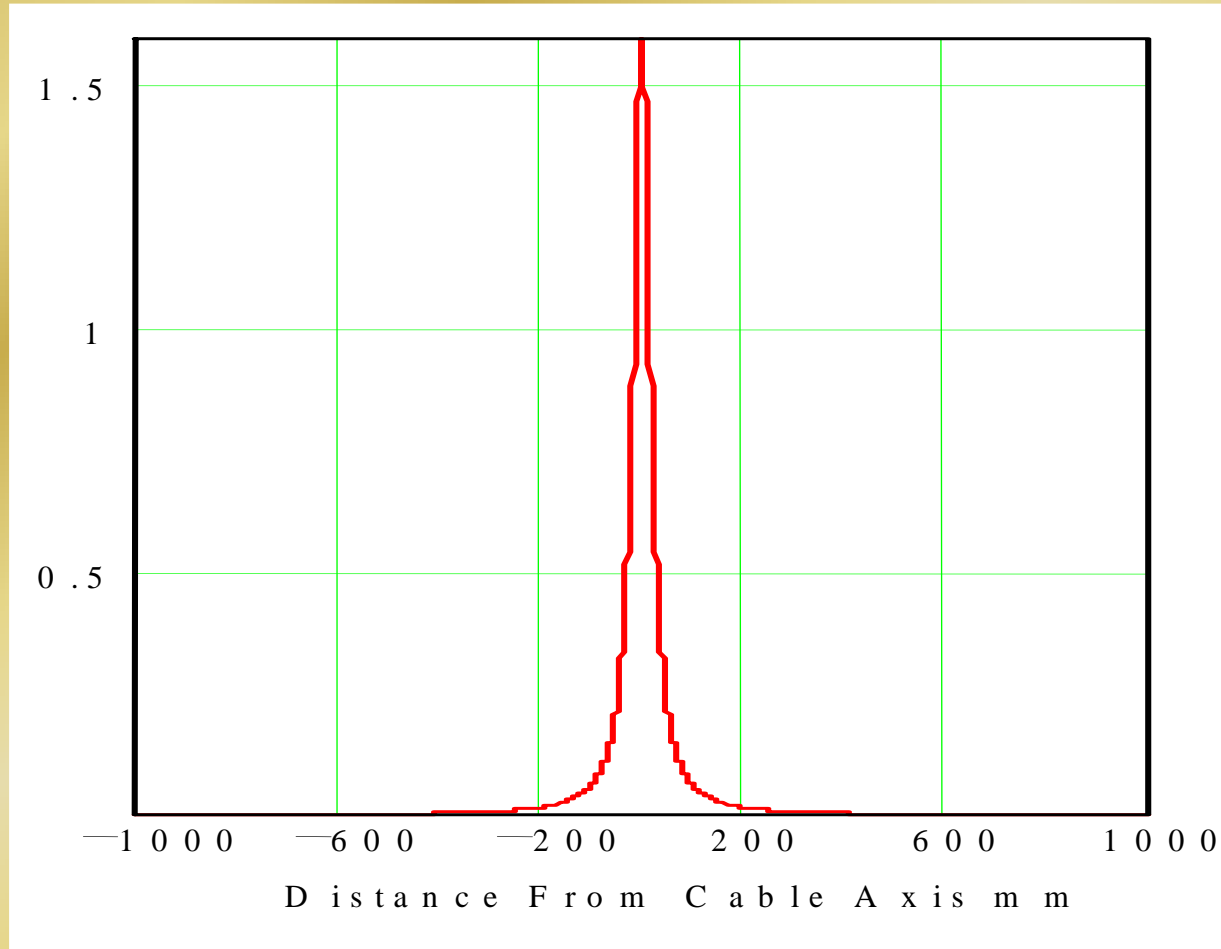

UK OGP Industry Driver

In 1994 the CRINE initiative was implemented,

CRINE

Cost **R**eduction **I**nitiative in the **N**ew **E**ra



The Shearwater Challenge

Conceptual Design Indicators

350 - 500 km of specialised cables

at an estimated cost of

£1.5 - £2.5 million.

Cost Reductions Required



Initial Saving Estimates

Early estimates suggested a reduction of:

30% total installed cable costs

and

20 tonnes of topsides weight



Issues to be Resolved

- Evaluation of Sheathing Materials
- Diameter and Weight Savings
- Fault Rating (Bursting Forces)
- Installation Characteristics
- Earthing & Bonding Segregation
- Terminating & Glanding
- Zone 1 Applications
- Independent Risk Review
- Cost Reduction



Evaluation of Sheathing Materials

- **Chlorosulphonated Polyethylene**
- **Ethylene Vinyl Acetate**
- **Oil Resisting EVA (R-HF-90)**
- **NIPLAS**
- **Thermoplastic LSF**
- **Def Stan 61 - 12 Part 31**



ELASTOMERIC					
	INSULATION		SHEATH		
	EPR	BS6883 TYPE B	BS6883 TYPE D	NBR PVC	MOD (N)
TEMPERATURE					
MAX OPERATING TEMP	90	85	85	70	115
MIN OPERATING TEMP	-50	-35	-30	-35	-30
RESISTANCE TO EXTERNAL AGENTS					
OZONE	4	4	4	4	4
OIL	1	3	2+	4	4
WATER	3	2+	2+	2+	4
CHEMICAL	2	3	2+	3	4
SOLVENTS	1+	3	3	3	4
ABRASION	2	2+	2	2+	4
MECHANICAL DAMAGE	1+	4	3	4	4
FIRE					
RETARDANCE	1	3	3+	3	3
HALOGEN GAS EMISSION	4	2	4	2	4
SMOKE EMISSION	2	1	4	1	3
OPERATIONAL					
FLEXIBILITY	4	4	4	4	4
MECHANICAL STRENGTH	1	2+	2	2+	3
DIELECTRIC STRENGTH	4	-	-	-	-
INSTALLATION EASE	4	4	4	4	4
	4	3	2	1	
	EXCELLENT	GOOD	FAIR	POOR	



THERMOPLASTIC ELASTOMERS

	INSULATION		SHEATH	
	STANDARD TPV	MODIFIED STANDARD TPV	OR TPV	FR TPV
TEMPERATURE				
MAX OPERATING TEMP	90	90	90	90
MIN OPERATING TEMP	-60	-60	-60	-60
RESISTANCE TO EXTERNAL AGENTS				
OZONE	4	4	4	4
OIL	1+	2+	4	2
WATER	3	3	3	3
CHEMICAL	2	2	2	2
SOLVENTS	2	2	2	2
ABRASION	3	3	3	3
MECHANICAL DAMAGE	4	4	4	3+
FIRE				
RETARDANCE	1+	2+	3	3+
HALOGEN GAS EMISSION	4	2	4	4
SMOKE EMISSION	4	2	4	4
OPERATIONAL				
FLEXIBILITY	4	4	4	4
MECHANICAL STRENGTH	3	2+	2+	2+
DIELECTRIC STRENGTH	4	-	-	-
INSTALLATION EASE	4	4	4	4
	4	3	2	1
	EXCELLENT	GOOD	FAIR	POOR



Oil Contamination

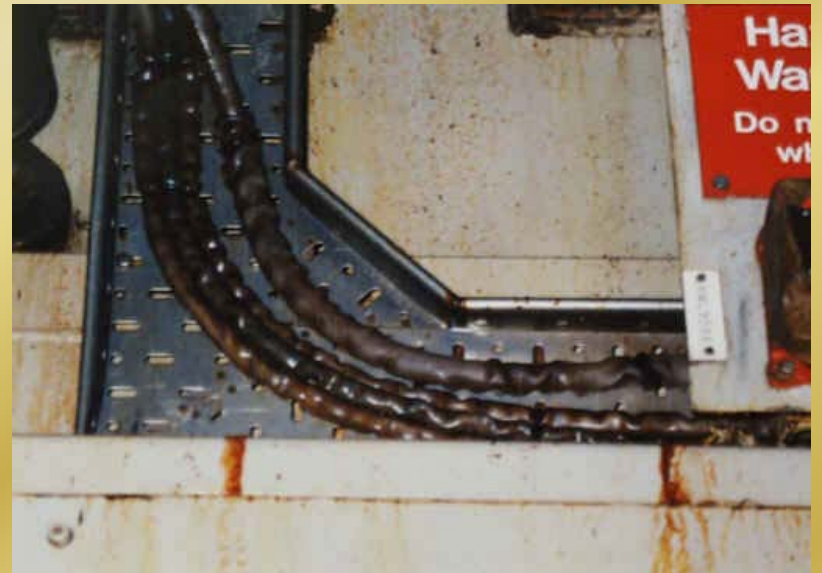

Sheathing Material Selection

B (SW2)

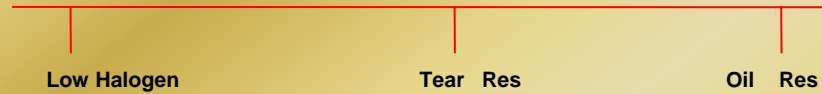

C (SW3)



D (SW4)

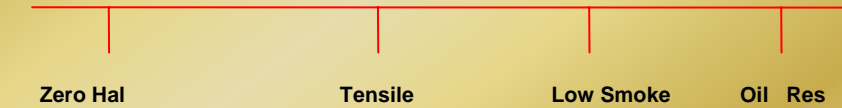

EVA

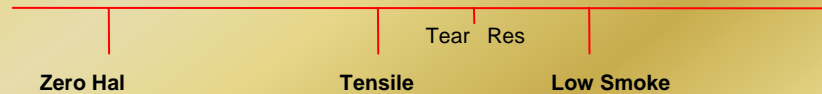

NIPLAS

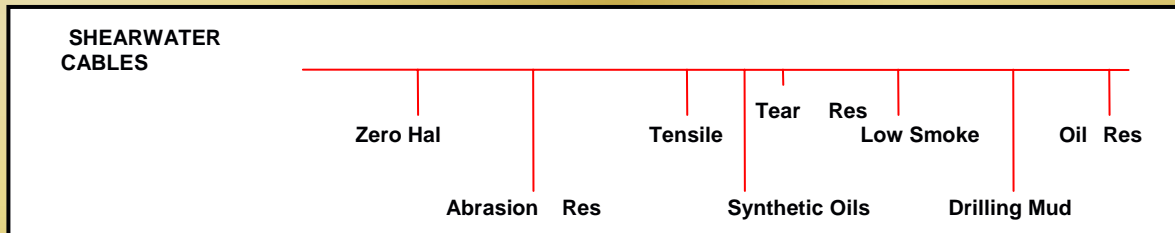

Evaluation of Sheathing Materials

(Continued)

After full cable performance evaluation the following combination of sheathing materials was finalised

Inner Sheath - Oil Resisting EVA (SHF2)

Outer Sheath - Def Stan 61-12 Part 31



Marine L.W.

in accordance with BS 6883 or IEC 60092 series

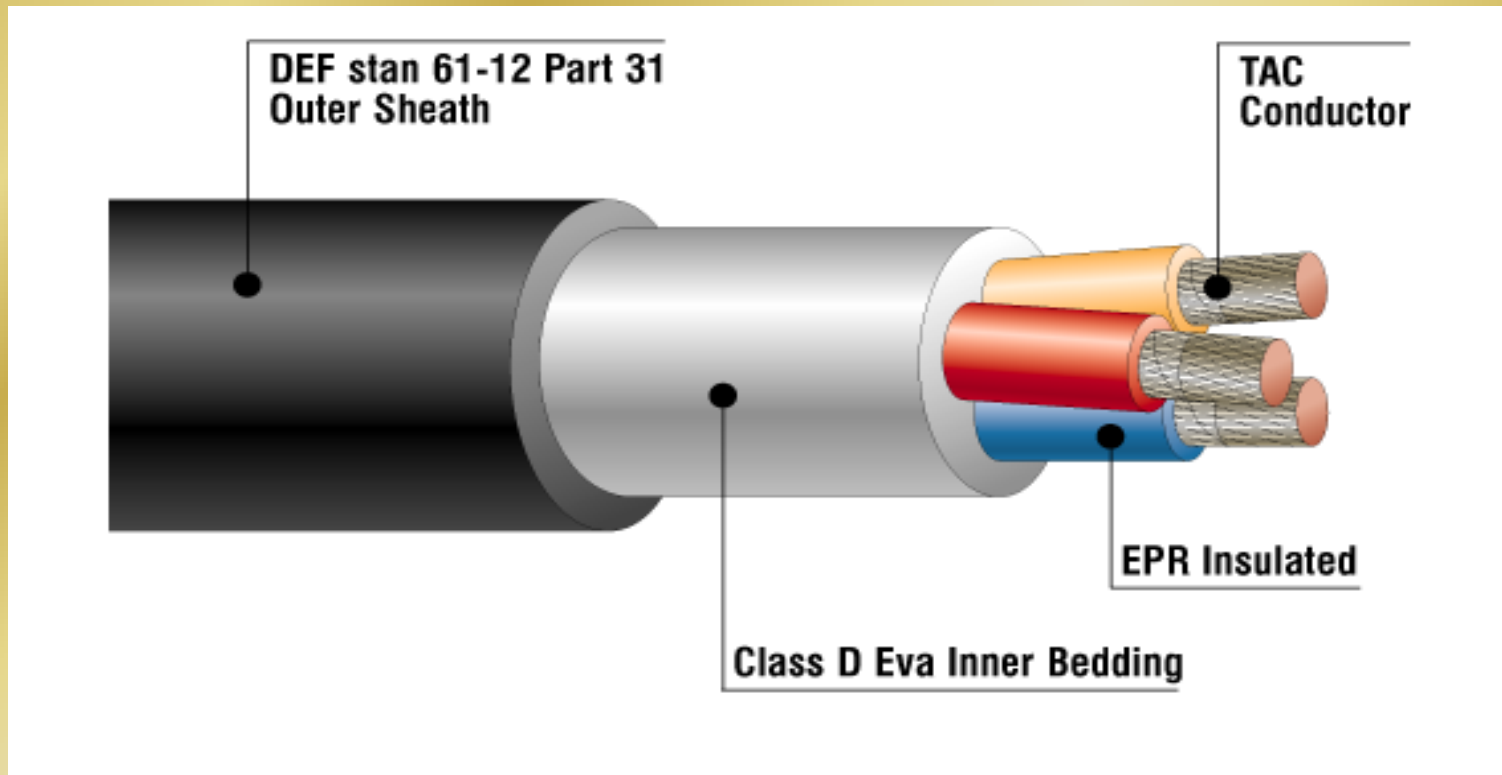

Marine L.W.

Power Cable

4X1.5sqmm

	Braid Armoured	Un-Armoured	% Saving
Overall Diameter	16	12	25
Nominal Weight	40	23	43

4x240sqmm

Overall Diameter	73	70	4
Nominal Weight	14512	12574	13



Marine L.W.

Instrumentation Cable

1x2x1.5sqmm

	Braid Armoured	Un-Armoured	% Saving
Overall Diameter	12	10	17
Weight	280	148	47

20x2x1.5sqmm

Overall Diameter	40	33	17
Weight	2321	1111	52



Armoured Marine L.W.

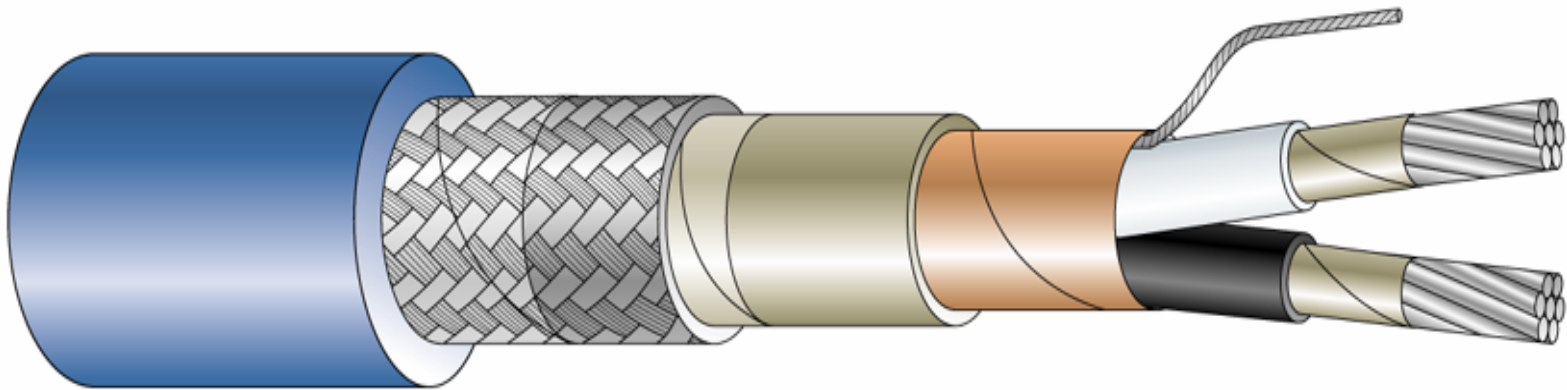

**ZH
Sheathed**

GSWB

**ZH Tape
Bedded**

**Screen
Insulated**

EPR or XLPE

**TAC
Conductor**



Armoured Marine L.W.

INSTRUMENTATION CABLE

1x2x1.5sqmm

	Braid Armoured Extruded Bedding	Armoured New Design	% Saving
Overall Diameter	12	10.9	9
Weight	280	118	58

20x2x1.5sqmm

Overall Diameter	40	30	24
Weight	2321	1170	50



Dimensions

- **All Low Voltage Power and Instrumentation cables are manufactured in accordance with the dimensional requirements of BS6883 or IEC 60092 series, for Un-Armoured Cables, with an additional outer skin of the sheathing material specified in UK Defence Standard 61-12 Part 31.**



Installation Characteristics

Pulling In Trials



Crush Test Equipment



Crush Tests

	1 Pr. x 2.5 sq.mm.	2 Pr x 1 sq.mm.	5 Pr x 1.5 sq.mm.	10 Pr x 1.5 sq.mm.
	Tonnes			
Braid Armoured	2 - 3	4.5 - 5	15 - 16	10 - 11
Marine LW	4 - 4.5	5 - 5.5	>16	>16
Standard Unarmoured	0.5 - 1	1 - 1.5	1 - 1.5	2 - 2.5



Installation Characteristics

Flexing

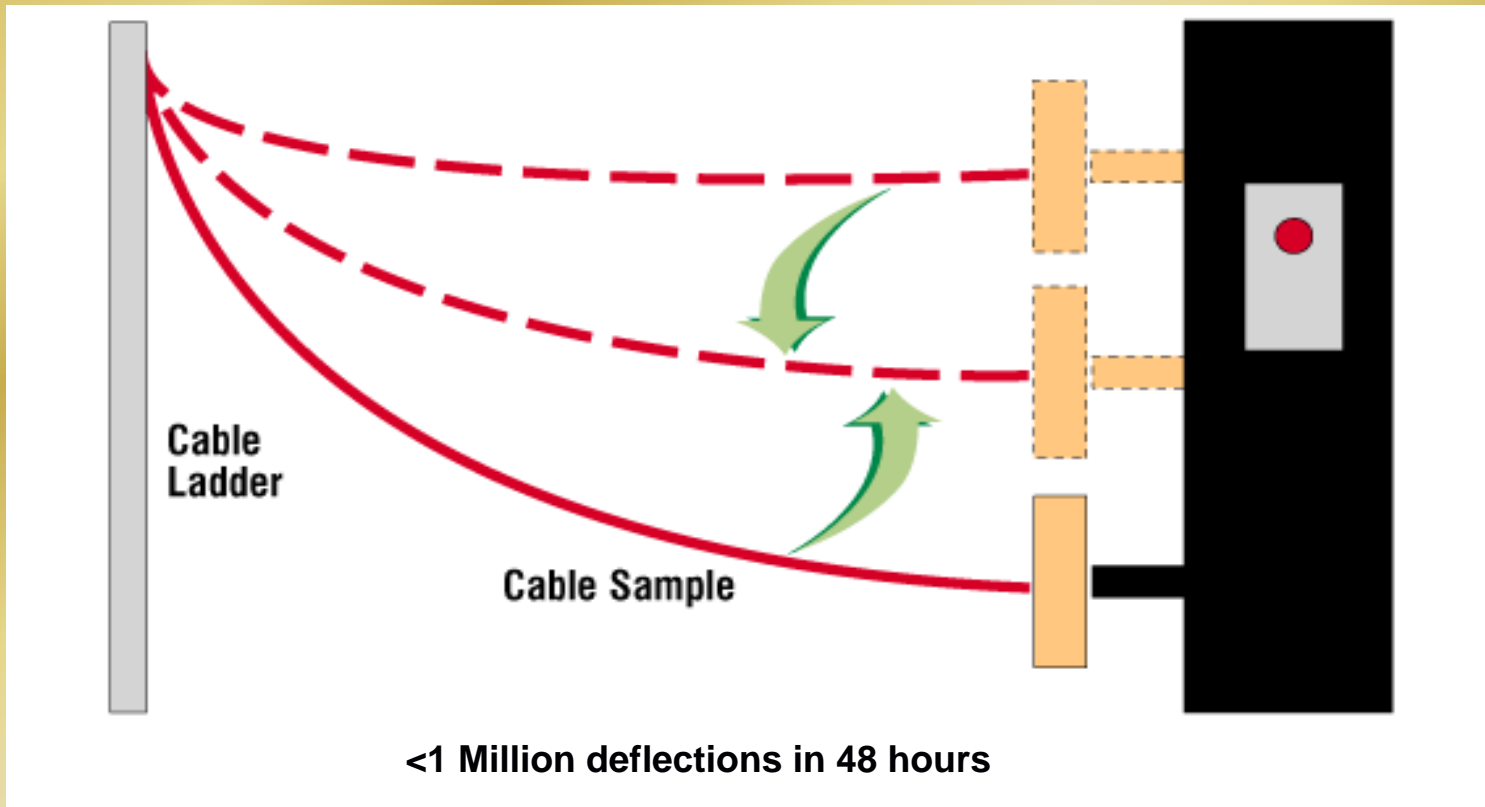

Fault Rating (Bursting Forces)

- Short circuit tests have been carried out by ERA
- Cables tested:

Single Core 300sqmm

Three Core 240sqmm



Earthing & Bonding

- **Removing the braid does not alter the basic earthing and bonding requirements necessary to maintain personnel safety and integrity of the installation's electrical system.**
- **The cable racking system is considered as a major part of the earth fault return path together with local bonding.**



Terminating & Glanding

- **No special tooling is required for the termination of Marine L.W.**
- **A new range of glands has been developed for the Shearwater Project, based upon the use of double seals on the outer sheath**



Cable Termination

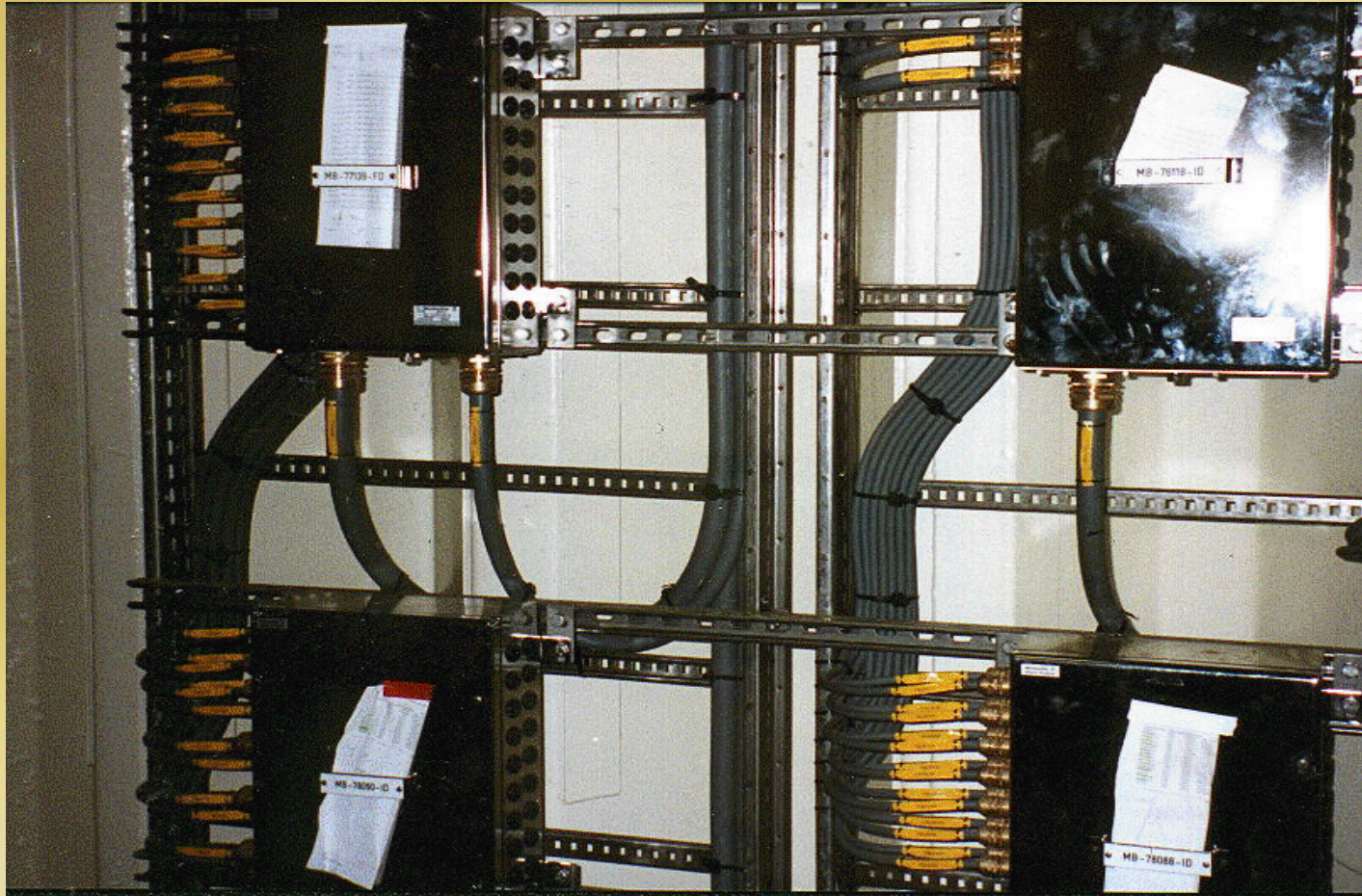

Independent Risk Review

- **Lloyds Register of Shipping were contracted to review the immediate and long term hazards and risk associated with unarmoured cables installed offshore.**
- **General Cable currently hold approvals for Unarmoured cables in accordance with,**



**Lloyds Register of Shipping
Det Norsk Veritas**



Installed Cable Cost Savings

- **Reduced Maintenance**
1500 hrs/year - £2.25M (15 Years)
- **Cable Weight**
60 tonnes saved, £420k
- **Site Waste**
5% saving, £70k
- **Commissioning**
Potential saving, £210k
- **CAPEX**
reduced by approximately £438k
- **Installation**
50% of Capital Cost £700k



Approximate Final Savings

Total Installed Cable Cost of

£4 Million Pounds

and

Approximately 60 tonnes of topsides weight



*UK - Shearwater Offshore Project
Most challenging North Sea project*

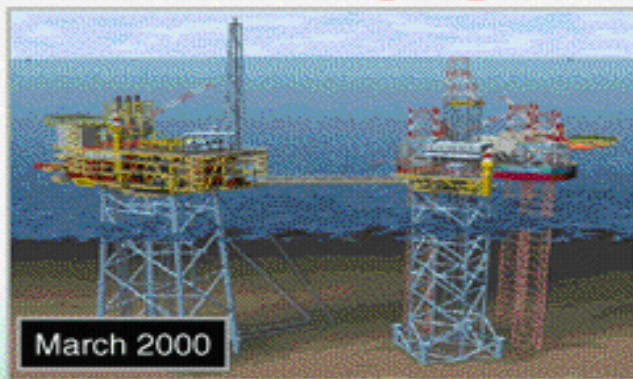

*Heaviest single lift offshore ever!
(11,600 tonnes)*

